

# AVERY DENNISON MARKETING SPECIFICATION

## HISTORY

THE SUBJECT MATTER DISCLOSED HEREIN EMBODIES PROPRIETARY INFORMATION WHICH IS THE CONFIDENTIAL PROPERTY OF THE AVERY DENNISON CO. NONE OF WHICH SHALL BE COPIED, REPRODUCED, DISCLOSED TO OTHERS, PUBLISHED OR USED IN WHOLE OR IN PART, FOR ANY PURPOSE OTHER THAN THAT FOR WHICH IT IS BEING MADE AVAILABLE WITHOUT THE EXPRESS ADVANCE WRITTEN PERMISSION OF A DULY AUTHORIZED AGENT OF THE COMPANY. THIS DOCUMENT IS THE PROPERTY OF THE AVERY DENNISON CO. AND IS TO BE RETURNED TO THE COMPANY ON DEMAND.

REV.	DATE	DESCRIPTION
A	6/01/10	RELEASE TO PRODUCTION
B	08.15.18	UPDATES TO NEW FORMAT; ADDED -0 TO PART NUMBER; ADDED SPECIAL CHARACTERISTIC NOTE; BALLOON 2 CHG TO 12.50

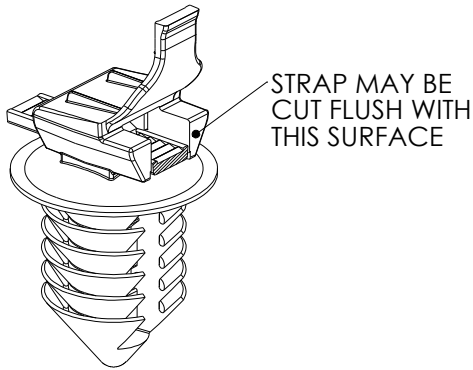
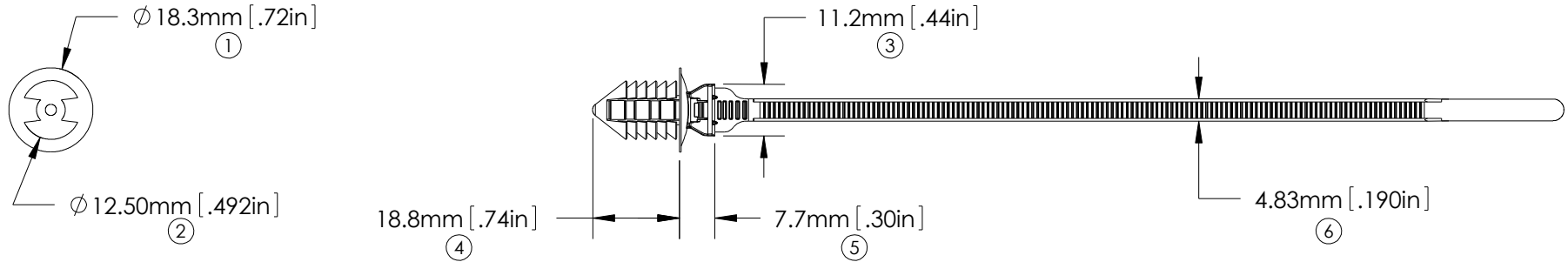

**ASSEMBLED VIEW**

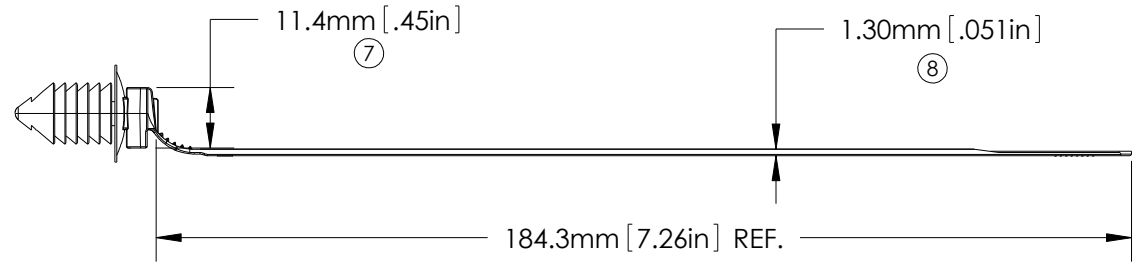

9	△ FLAMMABILITY RATING:	HB RATED PER FMVSS302
10	△ TENSILE STRENGTH:	222N / 50LBF MIN.
	MOUNTING:	Ø 11.50mm ± 0.25mm HOLE IN PANEL THICKNESS OF 0.7mm TO 8.5mm
	TEMPERATURE RANGE:	-40°F (-40°C) TO 229°F (115°C) CONTINUOUS AND 257°F (125°C) AT MAXIMUM EXPOSURE
	WEIGHT:	2.2g
	BUNDLE DIAMETER:	Ø 1.6mm [Ø .06in] TO Ø 44.5mm [Ø 1.75in]
	INSTALLATION TOOL:	12001 - HAND TOOL 12500 - PNEUMATIC TOOL
	TOOL TENSION SETTING:	6 - 8
	PACKAGING:	500/BAG, 5,000/CASE

NOTES:  
1. △ = INDICATES SPECIAL CHARACTERISTIC

APPROVALS:	ENG. APPR.	<i>Daniel Gilbertson</i>	08.15.18
	Q.A. APPR.	<i>Rick Estano</i>	08.15.18



FASTENER DIVISION  
FITCHBURG, MA 01420 U.S.A.  
TEL. 1-800-225-5913  
FAX. 978-353-8157

SPECIFIED TOLERANCES	
INCHES	[mm]
.XX ± .03	.X ± .7
.XXX ± .010	.XX ± .25
ANGULAR: ± 2°	

MATERIAL	<b>NYLON 6/6, IMPACT MODIFIED, HEAT STABILIZED</b>
COLOR	<b>BLACK</b>

DESCRIPTION	<b>11.5mm LOW INSERTION FIR TREE TIE</b>	
PART NO.	<b>20110-0</b>	REV. <b>B</b>